

# Swimming Pool Submittal Guide



Residential swimming pools must be set back from property lines at least 10' and may not be located any closer to the road than what the house sits. This includes any decking or concrete that may be placed around the pool. In addition, no swimming pool may be placed within any easements. Stormwater Controls may be required for decks, patios and walkways.

For above ground pools, at least 48" of pool wall must be exposed above ground in order to qualify as a barrier. If less than 48" of pool wall is exposed, a form of fencing is required. It can be done as a fence around the entire yard, around only the pool, or you can install the fencing that goes around the top of the pool walls. For inground pools, a minimum of a 4' high fence must enclose the pool. The pool may not be filled with water until the fence has been erected.

Swimming pools are covered by the building code (UCC). In order to submit an application to obtain a building permit, two copies of the following documents must be submitted to the Township:

1. Building Permit Application Form
2. Plot plan outlining the layout of the property and all structures currently on it. Must show where the pool is located and the distances that it will be placed from the property lines. If you are constructing a deck or adding concrete around the pool, the sizes (footprint, not living space) of the structures on the property must be shown. This should include the square footage of the deck or concrete around the pool if being constructed.
3. Worker's Compensation insurance for the pool installer as required on the application form.
4. Installation information for the pool. You may need to request this from your pool installer.
5. Electrical information explaining how the electric will be supplied to the pool.
6. Information on what type of pool you plan to install. You can use the flyers that most of the pool companies supply.
7. If constructing a deck, "blue print" type designs showing how the deck will be constructed. They can be drawn by hand. They do not need to be architectural plans.
8. \$25 Plan Review Fee (Payable to Windsor Township by check or cash)

It can take up to 15 business days from the date of your submission to get a Building Permit. Once the information, in full, is submitted to us, we will forward your application to Commonwealth Code Inspection Service. They are the Township's third party inspection agency that enforces the building code requirements. They will review the documents to make sure they meet code requirements. After they approve them, they will return them to the Township Office. The Building Permit will be drawn up. You will be contacted once the permit is ready for pickup. When you pick it up, the balance of the fees will be due. These fees will include:

1. Building Permit Fee – The Building Permit fee is based on the cost for the pool and installation – \$25 for projects costing less than \$5,000 or \$6 per \$1,000 for projects costing \$5,000 or more.
2. \$4 Fee to the State
3. \$15 Administrative Fee
4. Inspection Fees – There will be several inspections that will be required. The cost for the inspections can vary from \$100 to \$150. You will receive a packet listing these inspections when you pick up the Building Permit.

If you have any additional questions prior to application submittal, please contact Kipp or Deanna at 244-3512.

# Sample Drawing

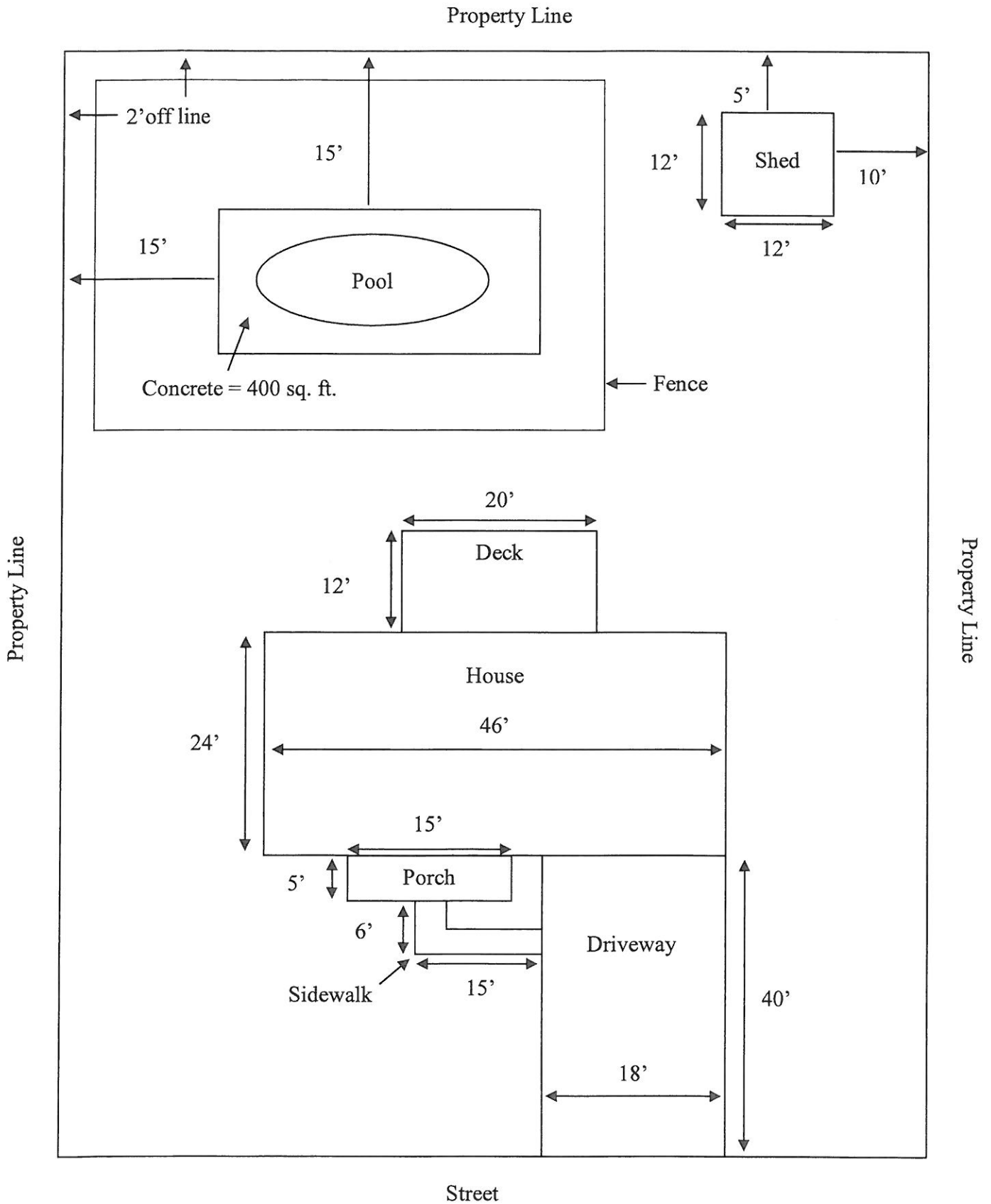

# POOL BARRIER REQUIREMENTS

Removeable pool ladder may serve as a barrier if the pool sides are a minimum of 48" above finished grade.

Features such as banks, walls, etc., that can be used for diving, shall be a minimum of 4' away from pool.

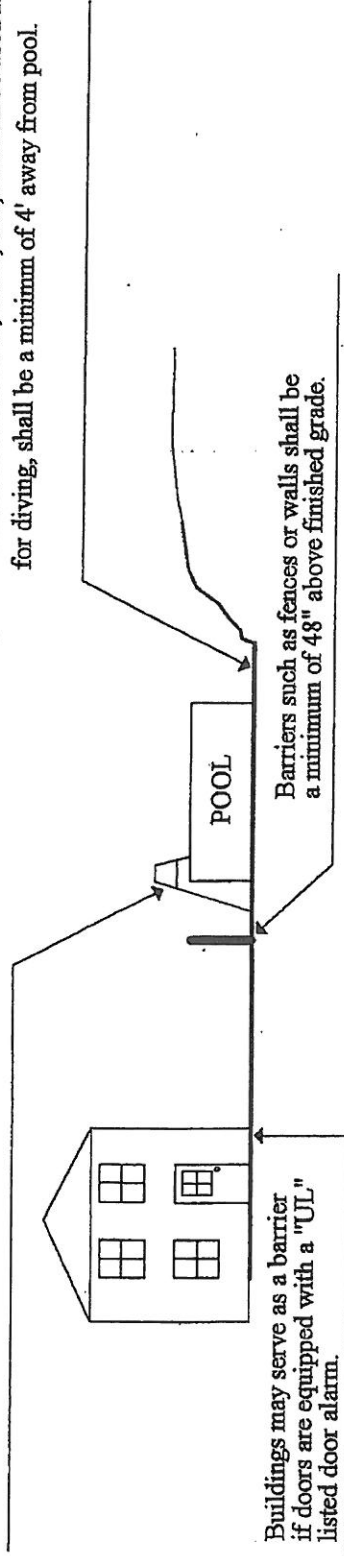

If latch is less than 48" above finished grade, latch shall be located on the inside, 3" below top, and no opening greater than 1/2" shall be located within 18" of latch.

Latch may be located on the inside or outside of the gate if is 54" minimum above finished grade

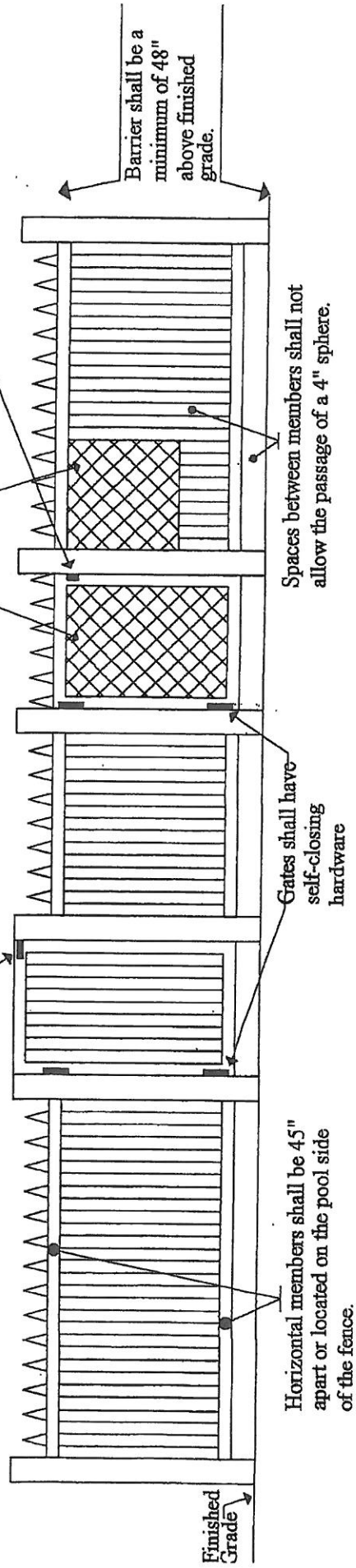

If the deck serves as a barrier to a swimming pool, the following code section applies:

## SECTION AG105

### BARRIER REQUIREMENTS

**AG105.2 Outdoor swimming pool.** An outdoor swimming pool, including an in-ground, above-ground or on-ground pool, hot tub or spa shall be surrounded by a barrier which shall comply with the following:

1. The top of the barrier shall be at least 48 inches (1219 mm) above grade measured on the side of the barrier which faces away from the swimming pool. The maximum vertical clearance between grade and the bottom of the barrier shall be 2 inches (51 mm) measured on the side of the barrier which faces away from the swimming pool. Where the top of the pool structure is above grade, such as an above-ground pool, the barrier may be at ground level, such as the pool structure, or mounted on top of the pool structure. Where the barrier is mounted on top of the pool structure, the maximum vertical clearance between the top of the pool structure and the bottom of the barrier shall be 4 inches (102 mm).
2. Openings in the barrier shall not allow passage of a 4-inch-diameter (102 mm) sphere.
3. Solid barriers which do not have openings, such as a masonry or stone wall, shall not contain indentations or protrusions except for normal construction tolerances and tooled masonry joints.
4. Where the barrier is composed of horizontal and vertical members and the distance between the tops of the horizontal members is less than 45 inches (1143 mm), the horizontal members shall be located on the swimming pool side of the fence. Spacing between vertical members shall not exceed 13/4 inches (44 mm) in width. Where there are decorative cutouts within vertical members, spacing within the cutouts shall not exceed 13/4 inches (44 mm) in width.
5. Where the barrier is composed of horizontal and vertical members and the distance between the tops of the horizontal members is 45 inches (1143 mm) or more, spacing between vertical members shall not exceed 4 inches (102 mm). Where there are decorative cutouts within vertical members, spacing within the cutouts shall not exceed 13/4 inches (44 mm) in width.
6. Maximum mesh size for chain link fences shall be a 2 1/4-inch (57 mm) square unless the fence has slats fastened at the top or the bottom which reduce the openings to not more than 13/4 inches (44 mm).
7. Where the barrier is composed of diagonal members, such as a lattice fence, the maximum opening formed by the diagonal members shall not be more than 13/4 inches (44 mm).
8. Access gates shall comply with the requirements of Section AG105.2, Items 1 through 7, and shall be equipped to accommodate a locking device. Pedestrian access gates shall open outward away from the pool and shall be self-closing and have a self-latching device. Gates other than pedestrian access gates shall have a self-latching device. Where the release mechanism of the self-latching device is located less than 54 inches (1372 mm) from the bottom of the gate, the release mechanism and openings shall comply with the following:

8.1. The release mechanism shall be located on the pool side of the gate at least 3 inches (76 mm) below the top of the gate; and

8.2. The gate and barrier shall have no opening larger than 1/2 inch (13 mm) within 18 inches (457 mm) of the release mechanism.

9. Where a wall of a dwelling serves as part of the barrier, one of the following conditions shall be met:

9.1. The pool shall be equipped with a powered safety cover in compliance with ASTM F 1346; or

9.2. Doors with direct access to the pool through that wall shall be equipped with an alarm which produces an audible warning when the door and/or its screen, if present, are opened. The alarm shall be listed in accordance with UL 2017. The audible alarm shall activate within 7 seconds and sound continuously for a minimum of 30 seconds after the door and/or its screen, if present, are opened and be capable of being heard throughout the house during normal household activities. The alarm shall automatically reset under all conditions. The alarm system shall be equipped with a manual means, such as touch pad or switch, to temporarily deactivate the alarm for a single opening. Deactivation shall last for not more than 15 seconds. The deactivation switch(es) shall be located at least 54 inches (1372 mm) above the threshold of the door; or

9.3. Other means of protection, such as self-closing doors with self-latching devices, which are approved by the governing body, shall be acceptable so long as the degree of protection afforded is not less than the protection afforded by Item 9.1 or 9.2 described above.

10. Where an above-ground pool structure is used as a barrier or where the barrier is mounted on top of the pool structure, and the means of access is a ladder or steps:

10.1. The ladder or steps shall be capable of being secured, locked or removed to prevent access; or

10.2. The ladder or steps shall be surrounded by a barrier which meets the requirements of Section

AG105.2, Items 1 through 9. When the ladder or steps are secured, locked or removed, any opening created shall not allow the passage of a 4-inch-diameter (102 mm) sphere.

**AG105.3 Indoor swimming pool.** Walls surrounding an indoor swimming pool shall comply with Section AG105.2, Item 9.

**AG105.4 Prohibited locations.** Barriers shall be located to prohibit permanent structures, equipment or similar objects from being used to climb them.

**AG105.5 Barrier exceptions.** Spas or hot tubs with a safety cover which complies with ASTM F 1346, as listed in Section AG107, shall be exempt from the provisions of this appendix.

# ELECTRICAL TIPS FOR SWIMMING POOL INSTALLATIONS

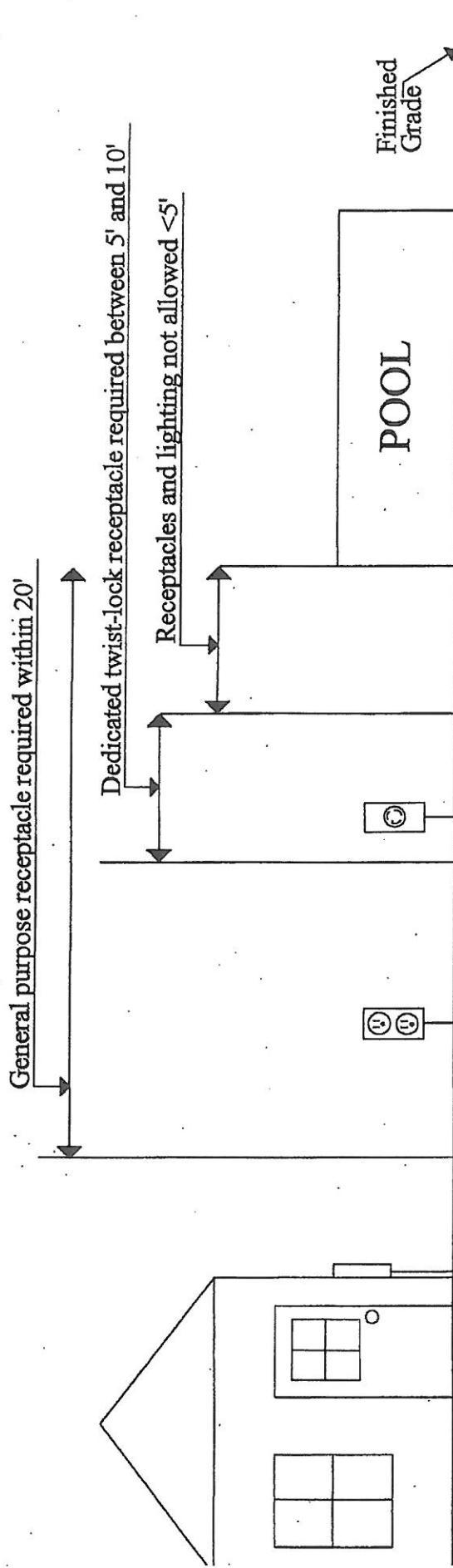

Branch circuit for permanent pools (those capable of being filled with over 42" of water) shall be pulled in electrical non-metallic tubing (pvc). Burial depth shall be a minimum of 18". Receptacles shall be GFCI protected.

Pool filters must maintain a 4' separation distance from the pool wall.

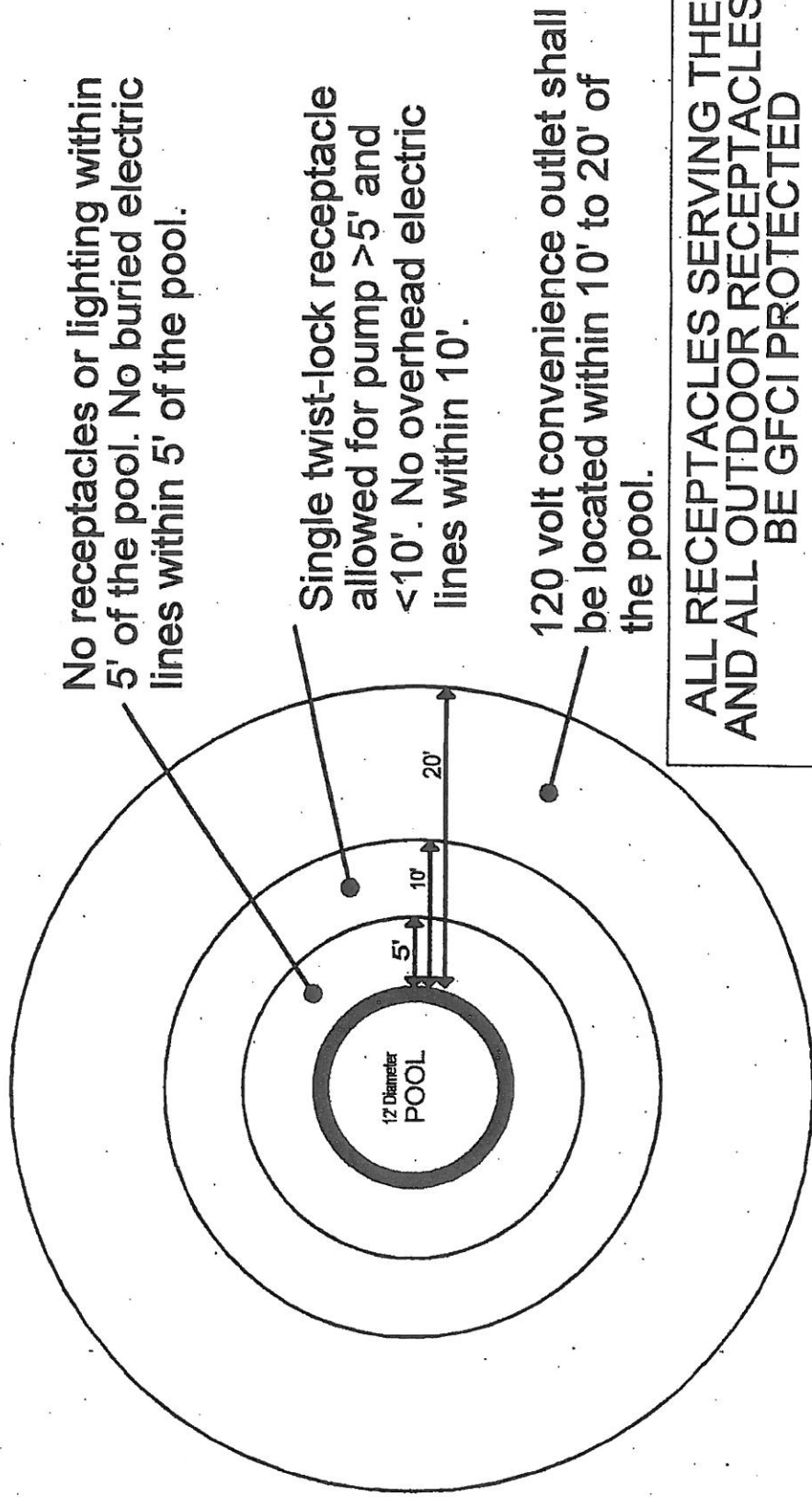

No receptacles or lighting within 5' of the pool. No buried electric lines within 5' of the pool.

Single twist-lock receptacle allowed for pump >5' and <10'. No overhead electric lines within 10'.

120 volt convenience outlet shall be located within 10' to 20' of the pool.

**ALL RECEPTACLES SERVING THE POOL AND ALL OUTDOOR RECEPTACLES SHALL BE GFCI PROTECTED**

\*\*\*Temporary Pools do not require a twist-lock receptacle. However, the outlet must be GFCI protected. No more than 25' of wire may be exposed above ground.